

AREMDE EQUIPMENT SPECIFICATIONS

UNIT DIMENSIONS

NEXUS ONE AND STYLUS ONE

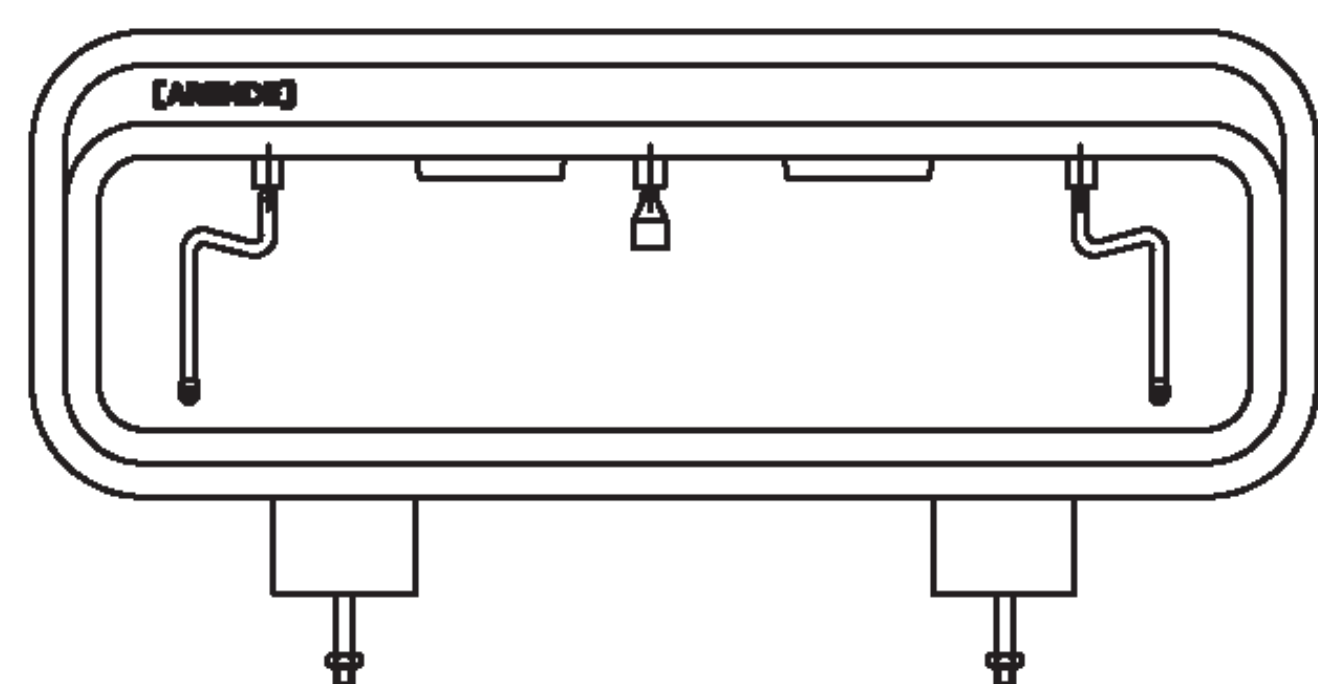
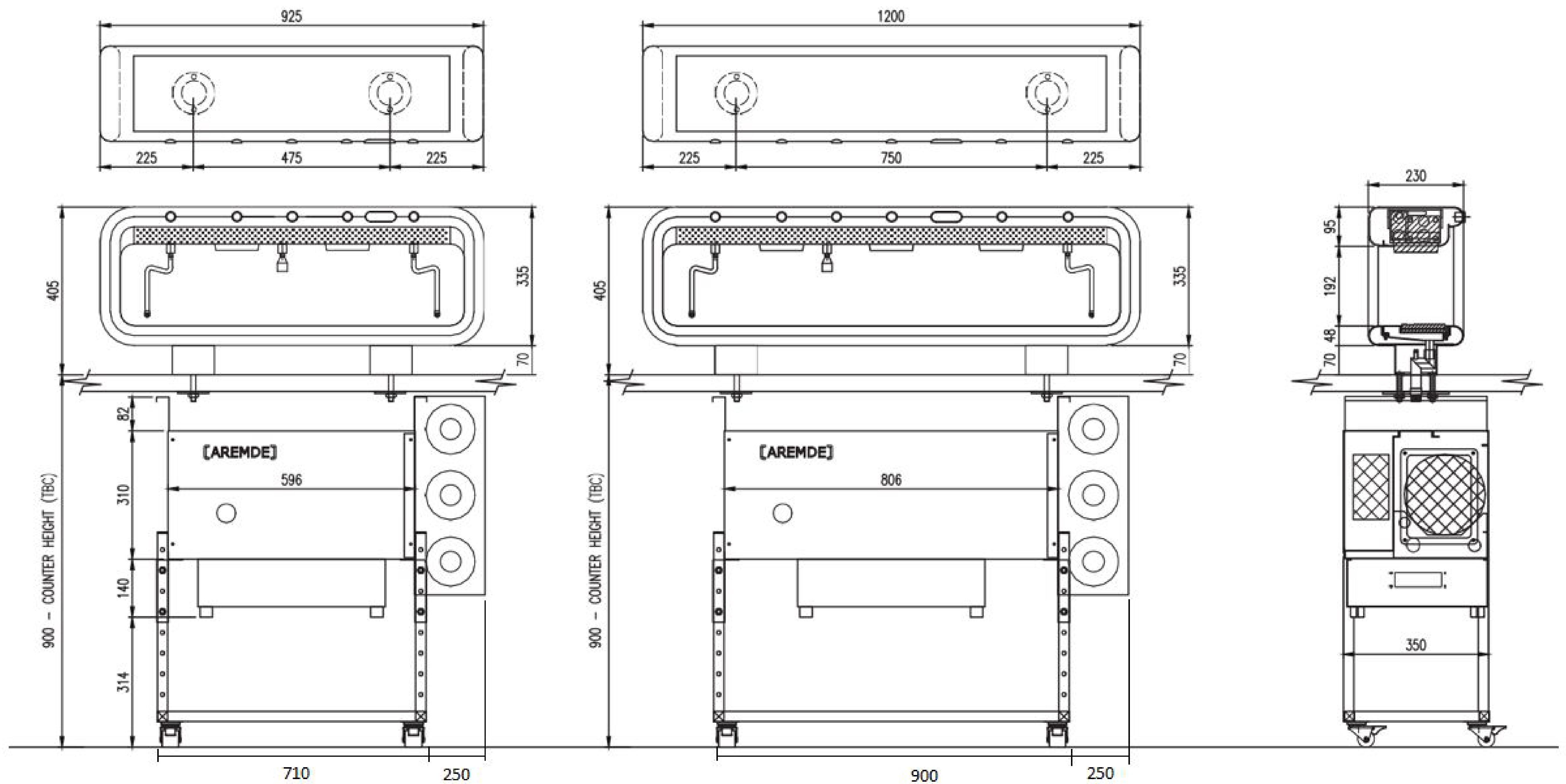

01 COFFEE MACHINE CTU
2 GROUP Scale 1:10

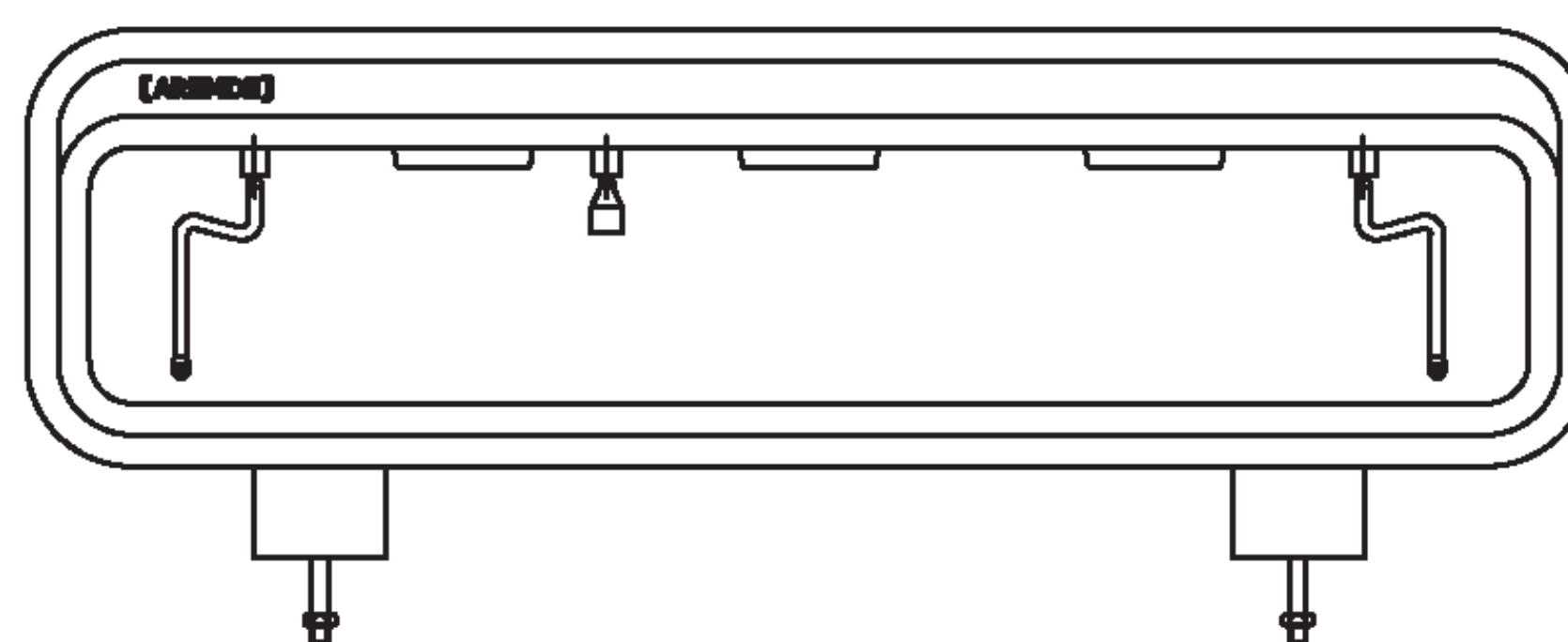

02 COFFEE MACHINE CTU
3 GROUP Scale 1:10

NOTE: Dimensions described also apply to STYLUS One model (2G and 3G)

UNIT COMPONENTS

NEXUS ONE AND STYLUS ONE

Diagram of components (NEXUS One and STYLUS One)

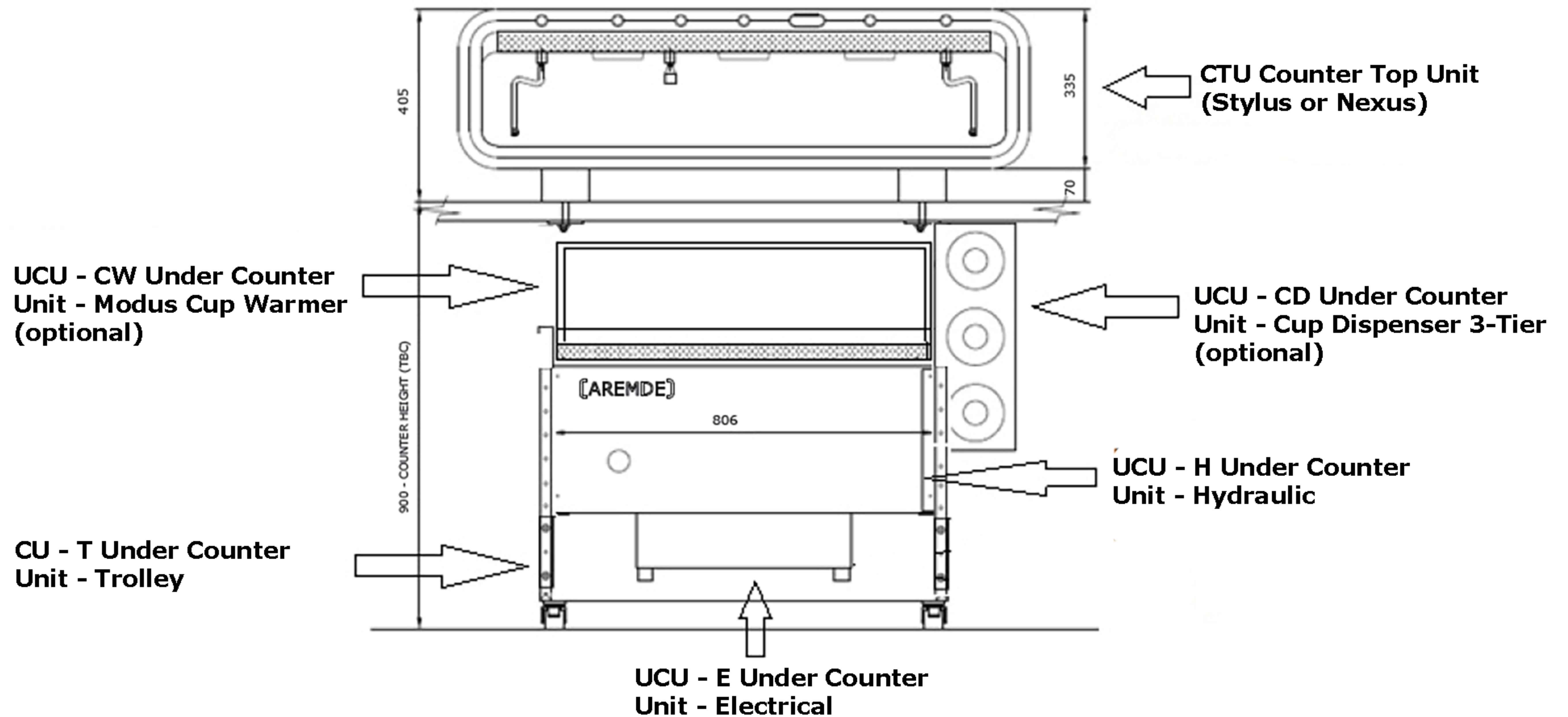

NOTE: Modus (Under Counter Cup Warmer) optional.

STYLUS One removable panel feature

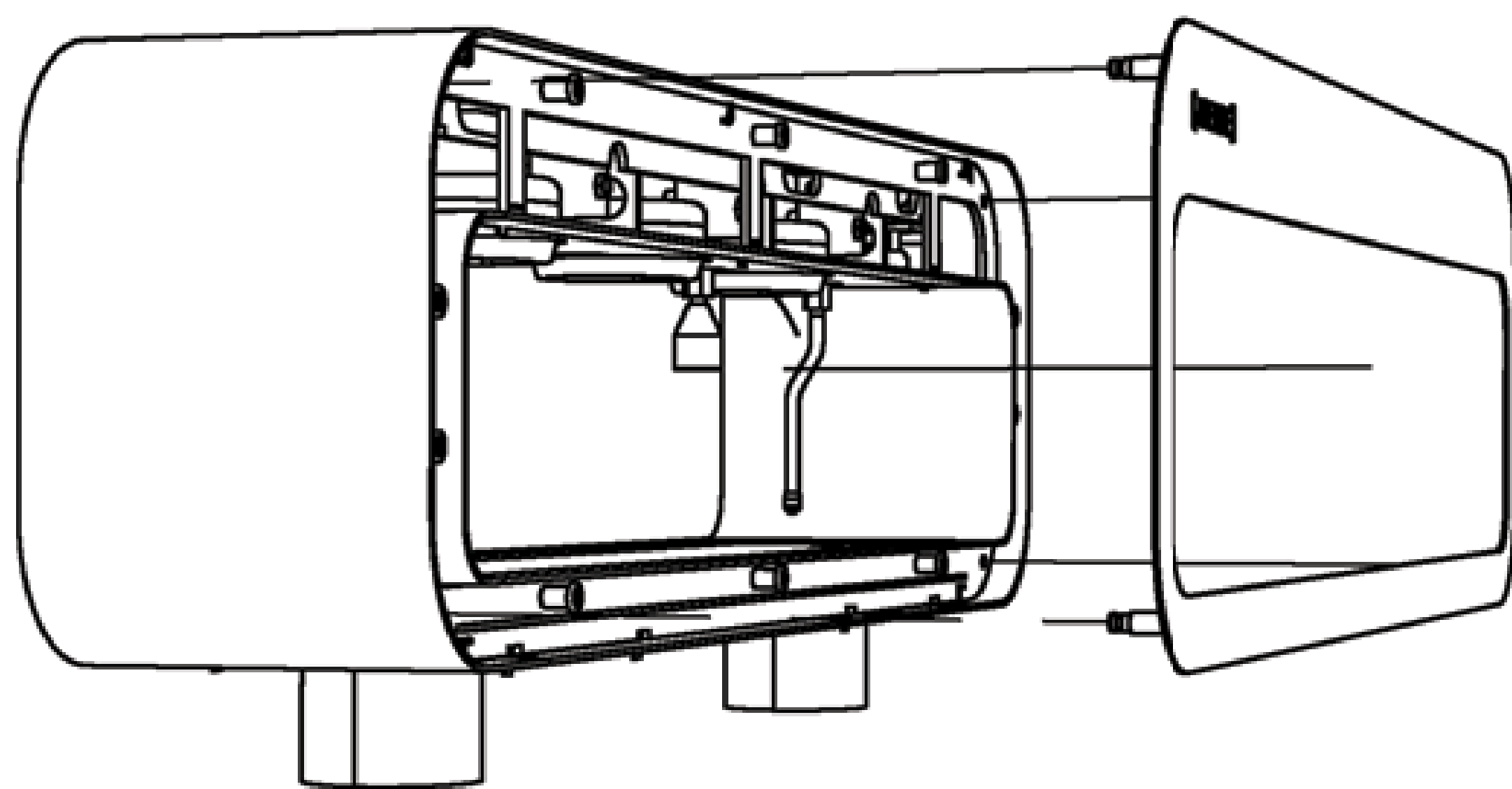

STYLUS One features removable front and back panels. Panels are powder coated and then vinyl print of chosen design is overlaid and hand cut to size.

Panels are attached to the chassis via magnets, with the addition of 4 guiding pins on each corner of the panel inserted into their corresponding female ports. This ensures correct alignment and secure attachment of panels.

Back barista-side panels must be installed, removed and replaced by qualified service technician as buttons and control board must be disconnected and reattached.

NEXUS ONE

TECH SPECS

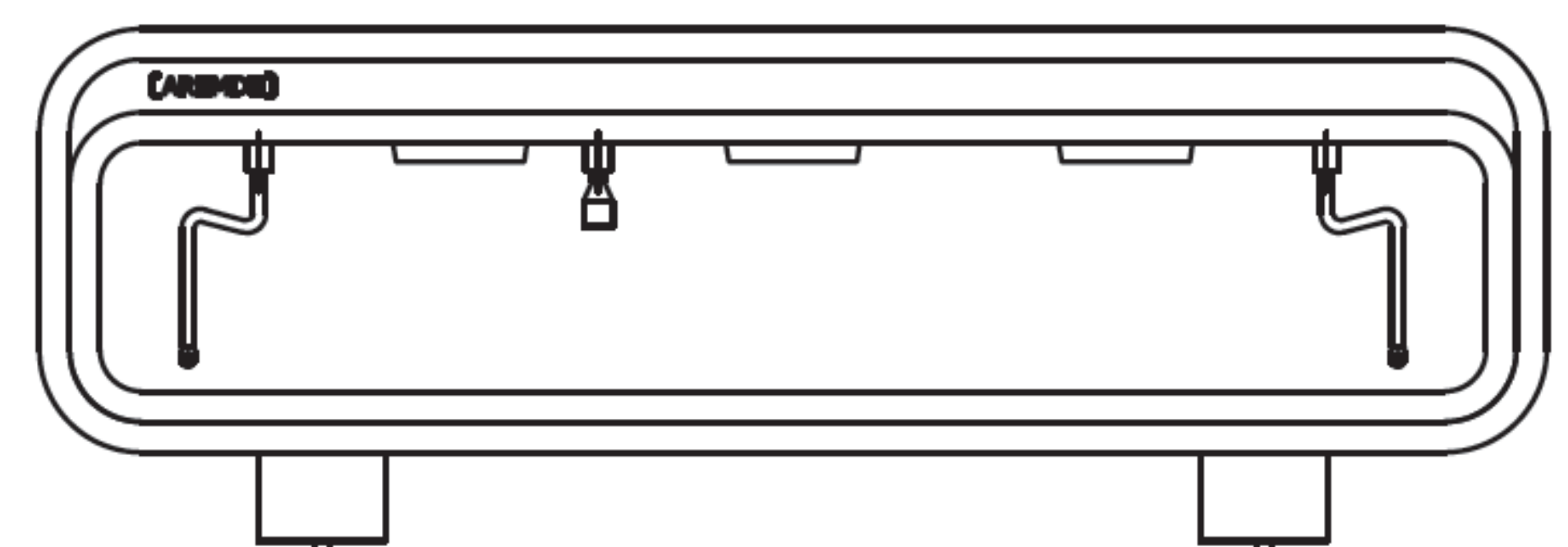
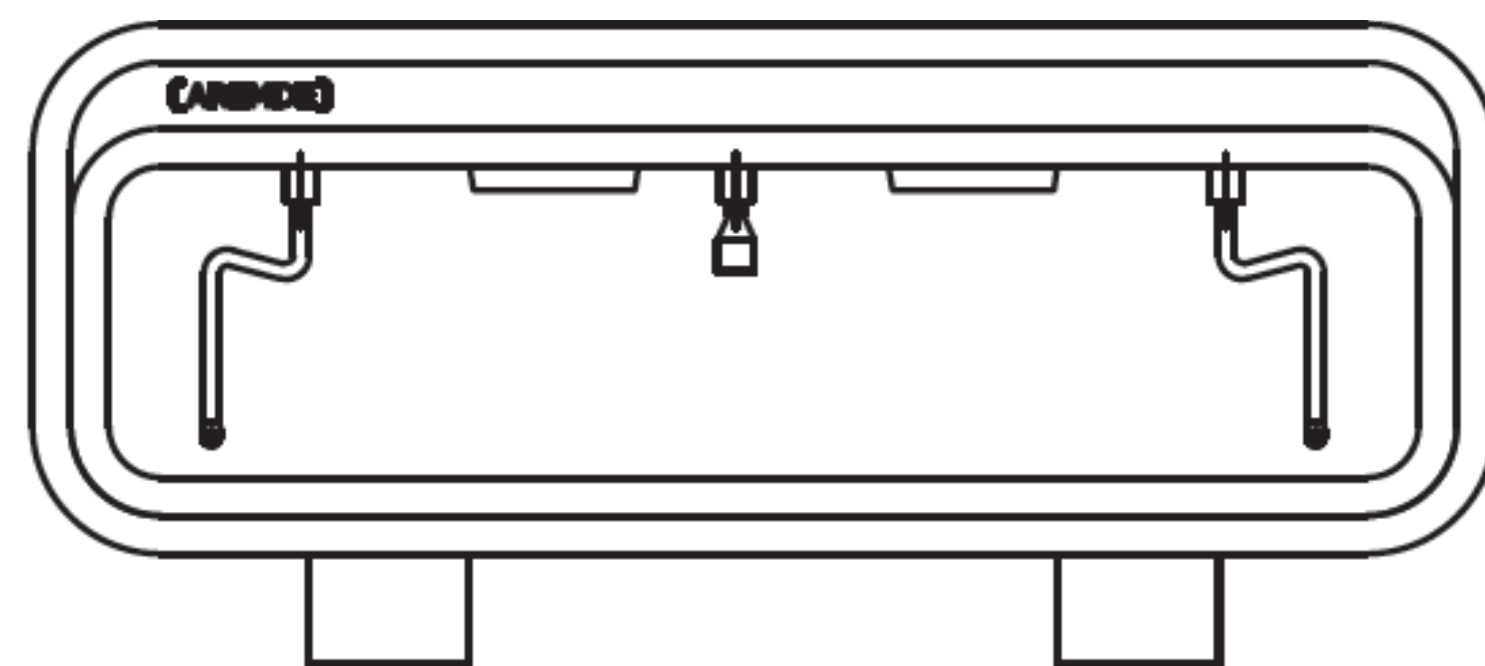

	2G NEXUS ONE	3G NEXUS ONE
BODY	Stainless steel - 304/316 - Acrylic polyurethane with clear-coat	
BOILER	14 Litre steam - 1 Litre coffee (per group)	17 Litre steam - 1 Litre coffee (per group)
HYDRAULICS	Digital - adjustable steam and coffee temperatures made with copper, brass and stainless steel	
GROUP	2 x brass/stainless steel - Composite	3 x brass/stainless steel - Composite
STEAM	Dedicated Boiler copper - stainless-steel - 1.2 or 1.5mm supplied	
HOT WATER	Built in Economiser Electronic Dosage	
CUP WARMER	Optional accessory - stand alone	
ELECTRONICS	PID controlled heating, Micro-computer PCB (programmable)	
DOSAGE	Volumetric or Extraction Weight Based (Wexus)	
POWER	5200w/7300w (steam 4500w, coffee 1300w per group, pump 180w)	10100w/9700w (steam 5200w, coffee 1300w per group, pump 180w)
VOLTAGE	220-240VAC 50/60Hz - (240VAC - 32AMP)	220-240VAC 50/60Hz - (240VAC - 40AMP)
DIMENSIONS		
CTU*	L:710 (27 15/16"), D:346 (16 9/16"), H:512 (20 3/16")	L: 1200 (48 11/16"), D: 230 (9"), H: 405 (15 15/16")
UCU** A-Hydra	L:604 (23 14/16"), D:346 (16 9/16"), H:142 (5 9/16")	L: 860 (33 14/16"), D: 346 (16 9/16"), H: 512 (20 3/16")
UCU-B-Elec	L: 604 (23 14/16"), D:346 (16 9/16"), H:142 (5 9/16")	L: 604 (23 14/16"), D: 346 (16 9/16"), H: 142 (5 9/16")
WEIGHT	95kg (CTU 40kg, UCU Electrical 15kg, UCU 40kg)	110kg (CTU 50kg, UCU Electrical 15kg, UCU 45kg)

STYLUS ONE

TECH SPECS

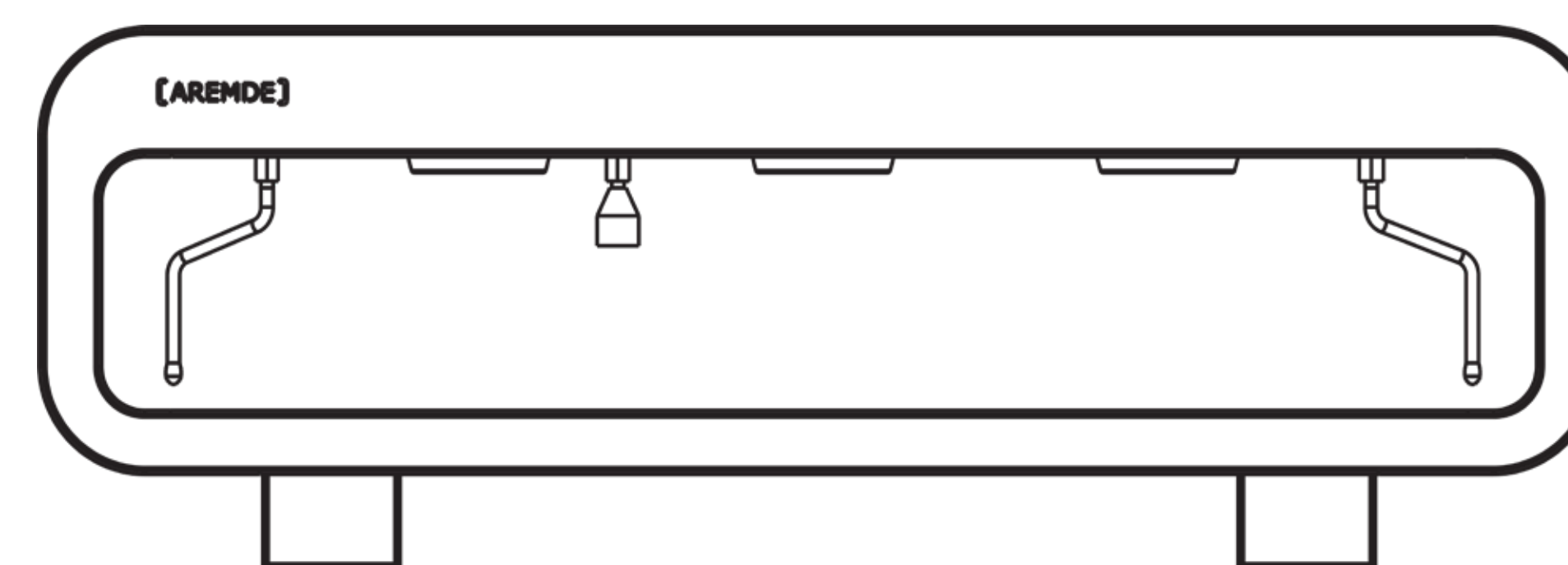
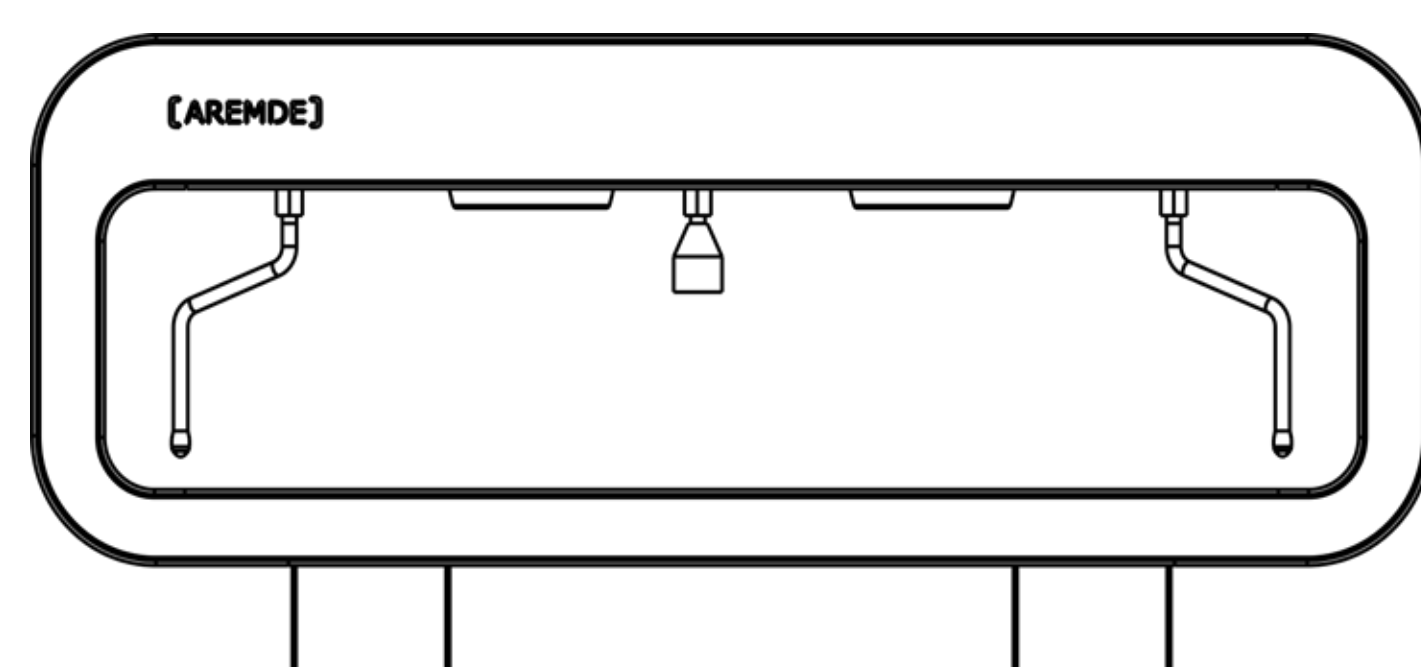

	2G STYLUS ONE	3G STYLUS ONE
BODY	Stainless steel - 304/316 - Powder coated Removable front and back panels	
BOILER	14 Litre steam - 1 Litre coffee (per group)	17 Litre steam - 1 Litre coffee (per group)
HYDRAULICS	Digital - adjustable steam and coffee temperatures made with copper, brass and stainless steel	
GROUP	2 x brass/stainless steel - Composite	3 x brass/stainless steel - Composite
STEAM	Dedicated Boiler copper - stainless-steel - 1.2 or 1.5mm supplied	
HOT WATER	Built in Economiser Electronic Dosage	
CUP WARMER	Optional accessory - stand alone	
ELECTRONICS	PID controlled heating, Micro-computer PCB (programmable)	
DOSAGE	Volumetric	
POWER	5200w/7300w (steam 4500w, coffee 1300w per group, pump 180w)	10100w/9700w (steam 5200w, coffee 1300w per group, pump 180w)
VOLTAGE	220-240VAC 50/60Hz - (240VAC - 32AMP)	220-240VAC 50/60Hz - (240VAC - 40AMP)
DIMENSIONS		
CTU*	L:710 (27 15/16"), D:346 (16 9/16"), H:512 (20 3/16")	L: 1200 (48 11/16"), D: 230 (9"), H: 405 (15 15/16")
UCU** A-Hydra	L:604 (23 14/16"), D:346 (16 9/16"), H:142 (5 9/16")	L: 860 (33 14/16"), D: 346 (16 9/16"), H: 512 (20 3/16")
UCU-B-Elec	L: 604 (23 14/16"), D:346 (16 9/16"), H:142 (5 9/16")	L: 604 (23 14/16"), D: 346 (16 9/16"), H: 142 (5 9/16")
WEIGHT	95kg (CTU 40kg, UCU Electrical 15kg, UCU 40kg)	110kg (CTU 50kg, UCU Electrical 15kg, UCU 45kg)

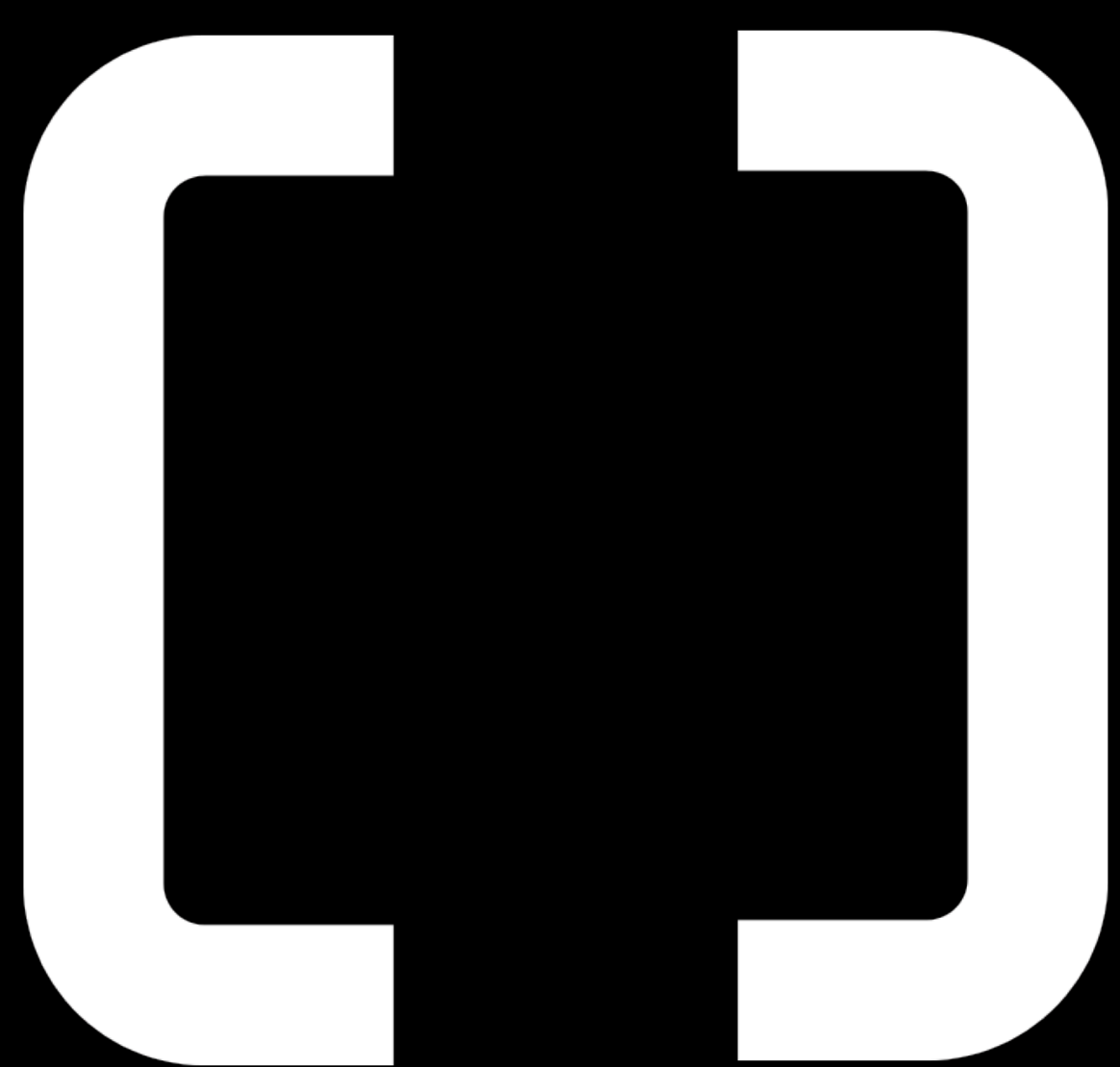

AREMDE COFFEE FUTURE REMADE